

Micro-Laser Range Finder Development: Using the Monolithic Approach

February 1999

John Nettleton, Dallas Barr, Brad Schilling, & Jonathan Lei
US ARMY CECOM RDEC NVESD
Fort Belvoir, VA

Samuel M. Goldwasser
Engineering Consultant
Bala-Cynwyd, PA

ABSTRACT

Laser range finders are a vital component of high precision targeting engagements. The precise and accurate range-to-target information is an essential variable in the fire control solution of today's sophisticated weapons. This range information is readily provided by the laser range finder, however, current fielded laser range finders are bulky, heavy, difficult to mount onto weapons, eye hazards and very expensive. The US Army CECOM RDEC NVESD is addressing these laser range finder issues in the development of a Micro-Laser Range Finder (mLRF). The mLRF is being developed for the soldier, with his special needs a top priority.

INTRODUCTION

The laser range finder is becoming an increasingly vital component of high precision targeting engagements for the individual soldier. The precise and accurate range-to-target information is an essential variable in the fire control solution of today's sophisticated weapons. This range information is readily provided by the laser range finder, however, current fielded laser range finders are bulky, heavy, difficult to mount onto weapons, eye hazards and very expensive. The US Army CECOM RDEC NVESD is addressing these laser range finder issues in the development of a Micro-Laser Range Finder (mLRF). The mLRF is being developed for the individual soldier, with his special needs a top priority.

The mLRF specifications for system physical characteristics requires a weight, with batteries, to be less than 1.25 pounds, a volume of less than 1.75" x 1.5" x 4", a simplified mode-select operation, and a provision for mounting to a weapon platform. The mLRF specifications for system performance characteristics requires four (4) range measurements per minute, +/- 1 meter or yard range resolution, a minimum range measure of 25 meters, and range performance in excess of 1500 meters to a 2.3 meter x 2.3 meter target. The mLRF's output wavelength will be 1.5 microns and will be Class I eye safe.

The development of the mLRF at NVESD is based upon use of a 'monolithic' approach. The monolithic approach reduces parts count, mitigates laser alignment complexity, and simplifies producibility. This makes the development and then fabrication of a very compact and affordable laser range finder feasible. This paper discusses the monolithic approach, the technical challenges faced, the results obtained, and conclusions reached during the development of the US Army NVESD's mLRF.

BACKGROUND

Several concepts using various laser technologies were investigated in developing the mLRF program strategy. Direct laser diodes, heterodyne laser diodes, diode-pumped solid state, and flashlamp-pumped solid state was all considered. The direct laser diode was desirable because it had the promise of being the smallest (form) and least expensive (affordability) alternative, yet, it severely lacked in performance (function). For example, the commercially available range finders by Bushnell, Tasco, Weaver, etc. are very low cost, marginally compact but ranges out to only several hundred meters reliably in bright sun conditions. The heterodyne laser diode concept was deemed complex and expensive (e.g. processors) but worthwhile for future investigation. Diode-pumped solid state was not pursued due to expense of the diodes and that every laser house seemed to be pursuing this concept. The flashlamp-pumped solid state alternative was inexpensive, compact and robust over temperature. Its main drawback was the limited firing rate of a few shots per second. This limited firing rate of the flashlamp-pumped solid state still exceeded the requirement of the mLRF program so it was decided to use a flashlamp-pumped solid state source in the mLRF program.

The emphasis of the mLRF program at NVESD has been three-fold; function, form and affordability of the system. These considerations are stressed with equal importance in the developmental phase and trade-off determinations. For example, the performance (function) of the mLRF is improved using a large receiver optic at the expense of size and weight (form). The performance (function) of the mLRF can also be improved by using an InGaAs avalanche photodiode (APD) rather than an InGaAs PIN photodiode at the expense of system affordability.

It has been imperative that the mLRF program keeps all three priorities in focus, especially system affordability, when developing the mLRF system. It is easier to develop a mLRF without consideration to cost/producibility of the system. But what good is a mLRF if the Army can't afford it for the soldier?

mLRF DESIGN

MONOLITHIC LASER CAVITY

The proposed mLRF consists of several optical components fused into one 'block' or monolithic laser cavity. After determining that the mLRF program was to be a flashlamp-pumped solid state source, the laser solid state material had to be selected. Erbium glass, Nd:YAG, and Nd:YVO4 were considered with Nd:YAG being selected due to availability and robustness of the laser crystal and q-switch material. To convert the Nd:YAG's eye hazard 1.064 micron laser output to the eye safe 1.5 micron wavelength, both optical parametric oscillation (OPO) and Raman shifting were investigated. OPO was selected due to maturity and availability of crystals. Selection of the OPO material, KTA or KTP, was based on laboratory characterization and performance of the OPO materials. KTA was found to be slightly better performing so it was selected as the OPO material. Both external cavity OPO design and intra-cavity OPO design were investigated. The intra-cavity OPO design was selected due to its lower parts count. Figure 1 depicts the components of the Monolithic Optical Laser Cavity.

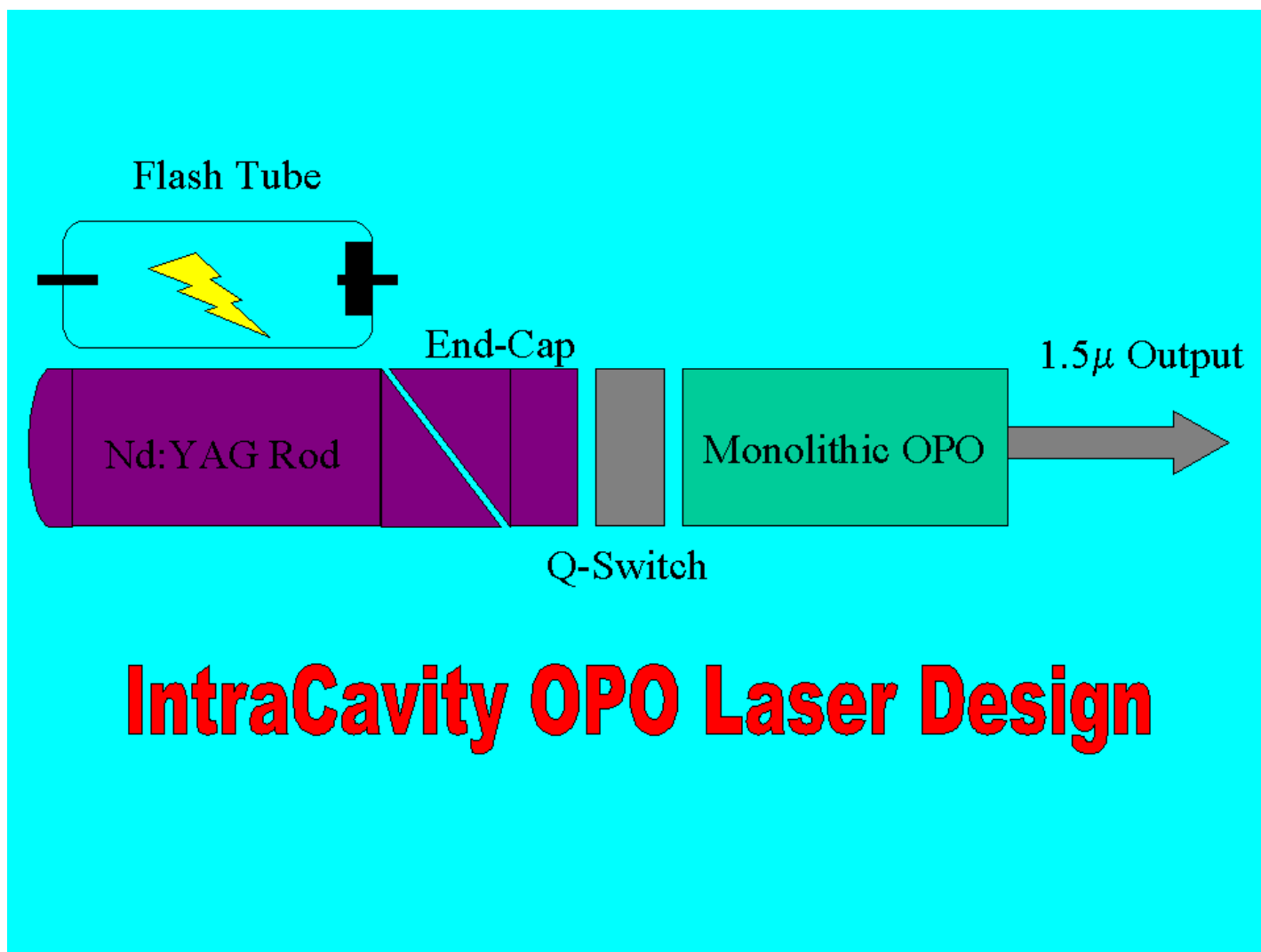

FIGURE 1. mLRF laser cavity component layout.

The optical components are bonded (diffusion or optical epoxy) to form one optical 'block'. All components are 'pre-aligned' during their fabrication process and then placed along an optically straight wall to form the optical laser cavity. The monolithic laser cavity fabricated at NVESD is shown in Figure 2. The H.R. Mirror can be flat or can have a radius-of-curvature (for ease of optical alignment of the cavity) ground into it. The Brewster angle cut is required for linearly polarized output as required for pumping the OPO cavity (e.g. to the 1.5 micron eye safe wavelength). This angle cut allows a crystal-to-air interface that selects polarization of the laser radiation. This polarization is essential for effective OPO conversion. The active material is Nd:YAG. The Q-switch is an optical passive device made from chromium YAG that is AR/AR coated. The OPO is KTA and it has the required optical coatings for a two-pass OPO cavity deposited on its faces.

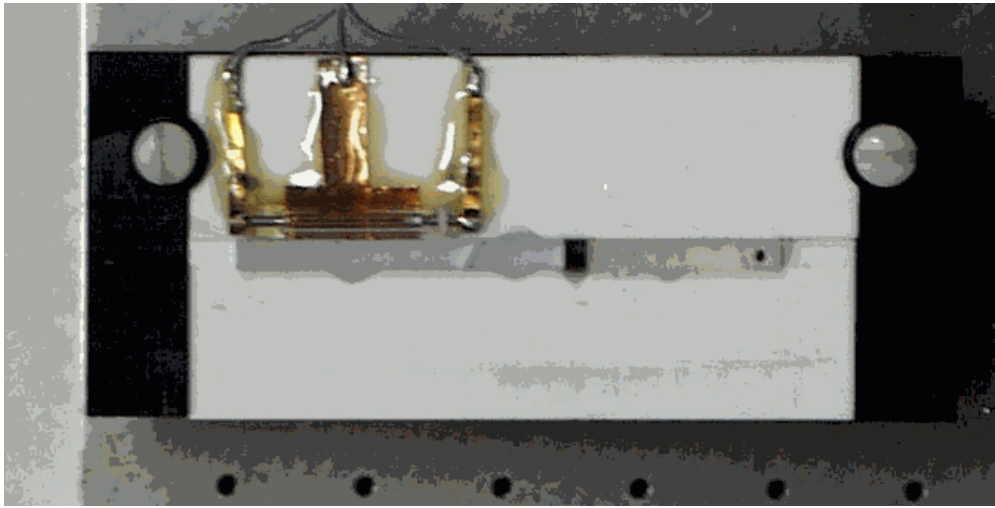
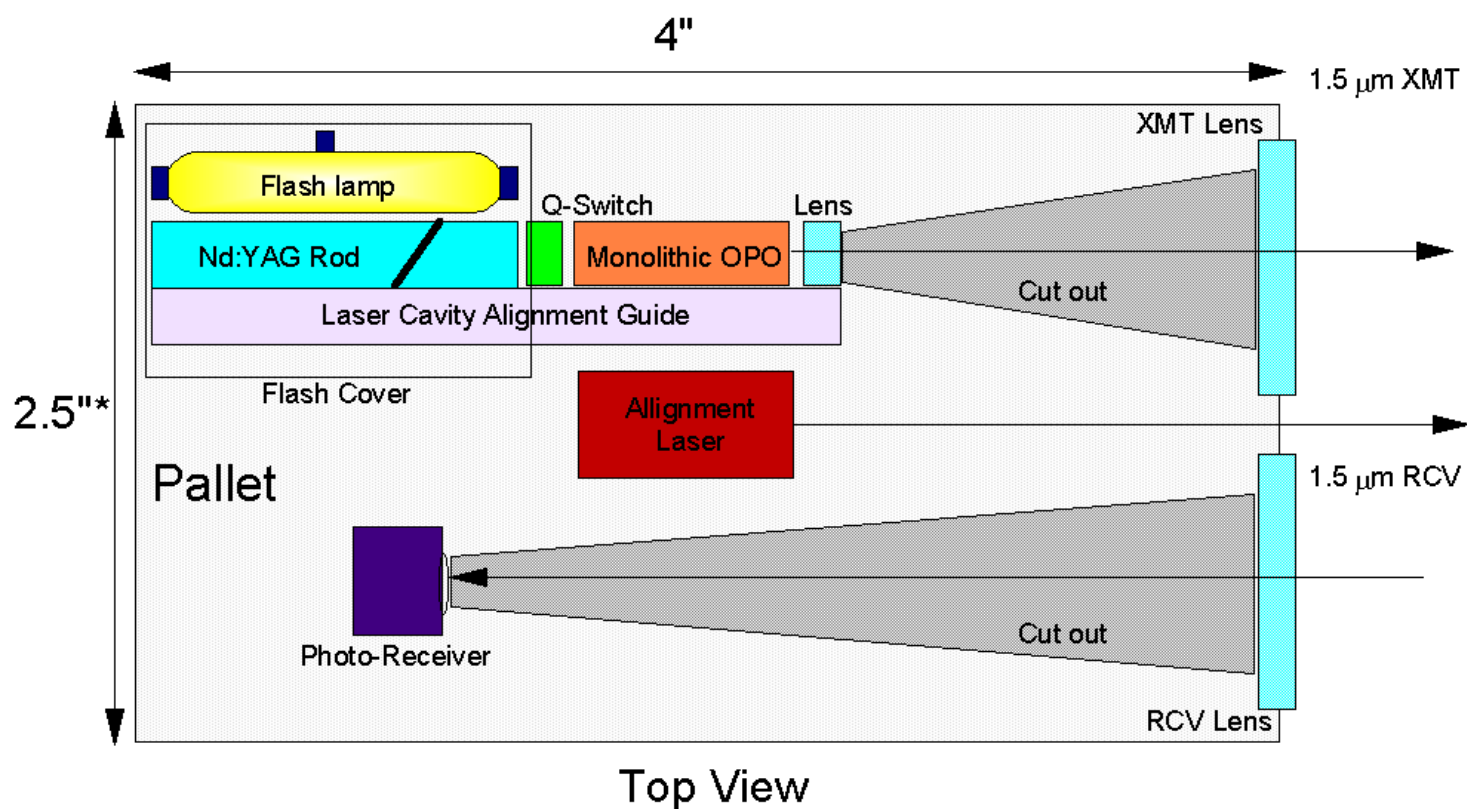

Figure 2. mLRF laser cavity.

The mLRF Monolithic Laser Cavity (MLC) simplifies the producibility of a laser range finder system. The fabrication of the mLRF can be done using batch processing. Large rectangular, pre-coated optical components can be joined together, optically aligned to form the laser cavity and then sliced to produce MLC modules. This batch process can greatly reduce the overall fabrication costs of the mLRF system.

The MLC module is ultra-compact. Its overall size is approximately 56 mm (L) x 3 mm (W) x 3 mm (H) as shown in Figure 2. The crystals that make up the MLC have a total weight of less than 1 gram! These dimensions are for a complete laser cavity! The MLC module is placed on a laser pallet for stiffness, mechanical stability. The laser pallet size is selected as part of the integration design trade. The extremely small size of the laser cavity allows for construction of a very compact, and lightweight, laser range finder. Figure 3 is a concept design of the mLRF system laser pallet.

Micro-Laser Range Finder Pallet Design



*Depends on size of XMT/RCV apertures...

Figure 3. Concept design of the mLRF system.

The MLC module requires none of the labor extensive alignment procedures as current laser range finders. No optical holders have to be fabricated, no complex engineering is required to design the optical cavity, and no precise laser cavity alignment(s) are required. Production labor and material costs can be greatly reduced.

ELECTRONICS – Microprocessor Controller

The mLRF system is centered on the use of a single-chip microprocessor controller. This controller performs power management, range processor calibration, laser condition sampling, laser triggering, range conversion (meters to yards), and range display control. Figure 4 is a logic flow diagram of the functions performed for a laser ranging operation.

The microprocessor controller performs power management of all the processing circuitry. The mLRF system is first turned on by depressing the CHARGE button. Pushing the CHARGE wakes up the power conditioners and the microprocessor controller. The controller then proceeds to take control and will charge the laser driver and power up the necessary electronic components. When the controller senses the proper charge voltage it gives a 'READY' to fire indication via the display unit. The controller then waits until the operator pushes the FIRE button to fire the laser and perform the ranging function. If the switch is not pushed within the set 'time out' period (about 10 seconds after charge) the unit will power down.

LOGIC FLOW

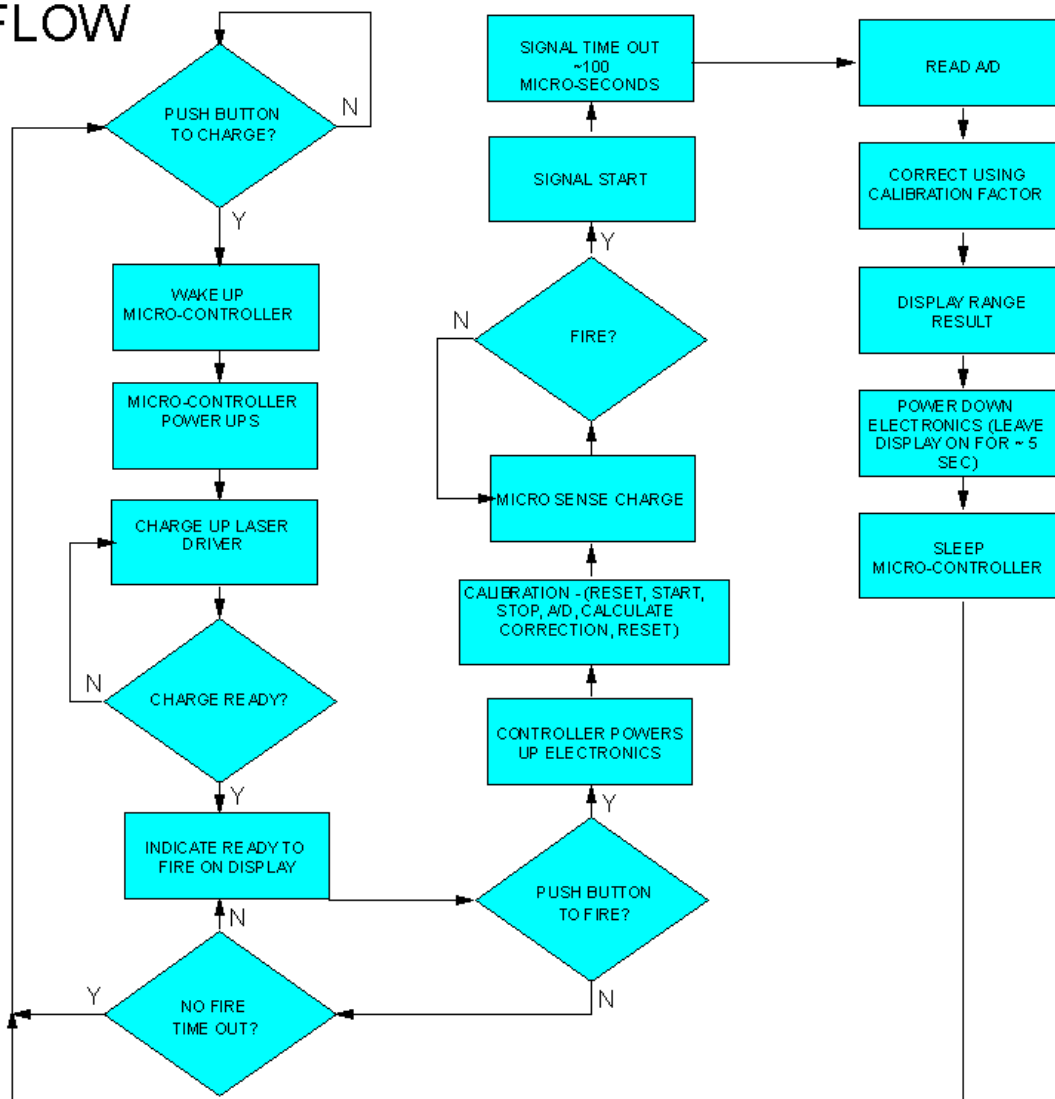

FIGURE 4. mLRF system control logic flow diagram.

When the FIRE button is detected to fire the laser, the controller performs several functions before actually firing the laser. The first function it performs is to turn on and clear/reset the range processing unit. The next step the controller takes is to power up the laser photoreceiver. The controller then pauses to allow the range processing unit and laser photoreceiver to come up to full power. The last function the controller does before firing the laser is to sense the charge voltage of the pulse forming network (pfn). This function is performed since the charge voltage fluctuates which can lead to a 'dead' or a reduced laser firing in a laser range finder system. The controller only fires the laser after sensing a proper charge voltage level in the charging circuit. If the proper level does not occur within a short period (10 msec) the controller will fire the laser anyway and annotate in the user range display that a charge fault occurred. These functions that the controller is required to do before firing the laser takes less than 100 milliseconds, thus the time it takes to perform these functions are transparent to the user.

When the laser fires, a Signal START pulse is detected by a START photoreceiver. This pulse initiates the timing function of the range processor. The time period is halted when a Signal STOP pulse is detected by the laser photoreceiver. The Signal STOP pulse is generated by the laser beam reflecting off the target and returning to the laser range finder system. Objects very close in may be ignored by installing a simple blanking function on the Signal STOP pulse line. The START and STOP pulses are signals to a time-of-flight range processor. The range processor has a 150 MHz clock rate for +/- 1 meter range resolution. The maximum range of the counter is 10 kilometers. Its package size is 1"1 x 0.7" w x 0.15" h.

A prototype electronics board has been constructed, programmed and de-bugged. This prototype electronics board integrated the power conditioning, the microprocessor controller, the time-of-flight processor, and several displays (LCD and LED). For test and de-bugging purposes timing circuitry was constructed to provide the protoboard with START and STOP signals.

ELECTRONICS – Flash & Pulse-Forming-Network (PFN)

A primary objective of the design for the flash and pfn was operation from a readily available power source – e.g. a 1.5 V AA battery, low cost, high efficiency, and small size. Fortunately, such a circuit does not need to be developed from scratch as this is similar to what is used in the electronic flash in popular "single

use" or disposable cameras. The units are widely available and very low cost (they are often available for the asking from 1-hour photo and camera shops).

The Kodak MAX flash unit was selected as a starting point since its circuit design was particularly amenable to modifications that would allow the microprocessor to control the charging and the firing of the flash. These flash units are all marvels of clever design and cost cutting. Figure 5 is a photo of the Kodak MAX flash circuit. The flash circuit consists of a transistor blocking oscillator using a miniature ferrite transformer running on a single 1.5 V AA Alkaline cell. Parts count is about as minimal as possible. The Kodak MAX Flash also includes a voltage limiter/regulator which provides feedback that the unit is READY to fire and provides for an automatic recharge. Both of these features are useful for the mLRF application. The flash itself was characterized and found to be an excellent match to pump Nd:YAG. The pulse width (50%) is about 125 microseconds and the optical energy provided by the MAX flash is approximately 2.7 joules.

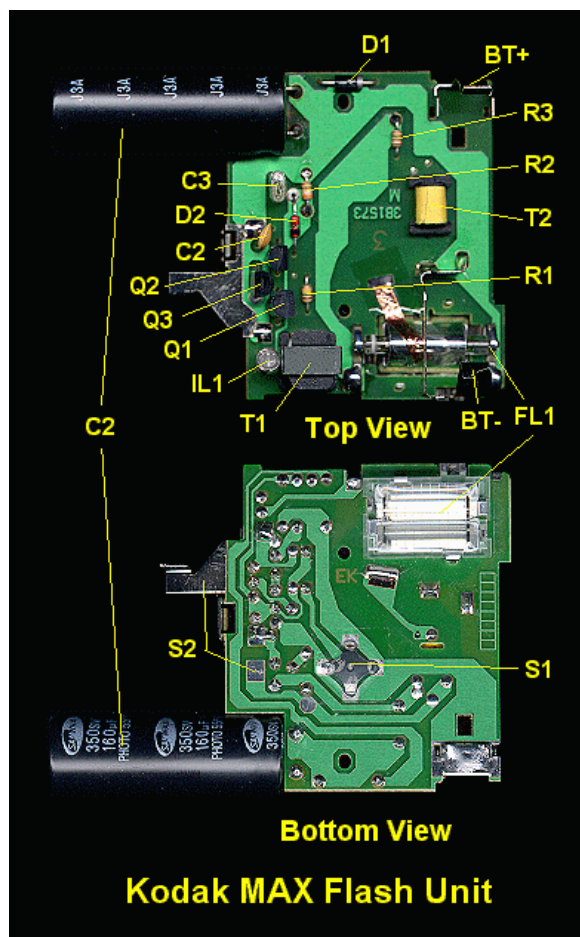

Figure 5. Circuit from a Kodak MAX flash camera

To interface with the controller, a small amount of additional discrete circuitry was added to control the inverter, to provide a READY feedback line to signal full charge, and to provide a flash trigger input (FIRE). These are all TTL compatible. The inverter will charge the pfn's main capacitor and then come on briefly as needed to maintain full charge. READY is asserted when the voltage on the capacitor reaches about 95 percent of full charge.

A logic triac replaces the shutter contacts so that a pulse on the FIRE line can trigger the flash. Clamp diodes were added on all the signal lines to logic Vcc and Gnd as insurance to prevent anything from making its way back to the controller - just in case there is crosstalk from the high current capacitor discharge pulse. Total isolation using opto-couplers would also be possible but would be more complex.

Prototyping was performed by adding a small mezzanine card to the existing MAX circuit board. A PCB board layout was then developed with a total size of about 2.25"l x 1"w x 0.7"h (excluding the battery) with the large energy storage capacitor overlying the other components. Some parts from the existing MAX circuit boards (notably, the inverter and trigger transformers) will be used where possible. Further size reduction using SMT parts should permit its size to be reduced by another 30 percent or more.

MODELED RESULTS

Modeling was performed to predict range performance of the mLRF system with respect to 1.5 micron laser output energy. Lasers95 was used to predict the 98% probability of detection range with a 0.001 false alarm rate for various conditions. The parameters of the modeling were selected to best fit the real mLRF system being designed.

- A one inch diameter receiver with an InGaAs APD detector in clear (23 km) and impaired (7 km) visibility was modeled.
- A one inch diameter receiver with a PIN InGaAs detector in clear (23 km) and impaired (7 km) visibility was modeled.

- And last, a one-half inch diameter receiver with a PIN InGaAs detector in clear (23 km) and impaired (7 km) visibility was modeled.

Figure 6 is a plot of the results of the modeling runs. The irregularities in the curves are due to rounding off the Lasers95 range predictions.

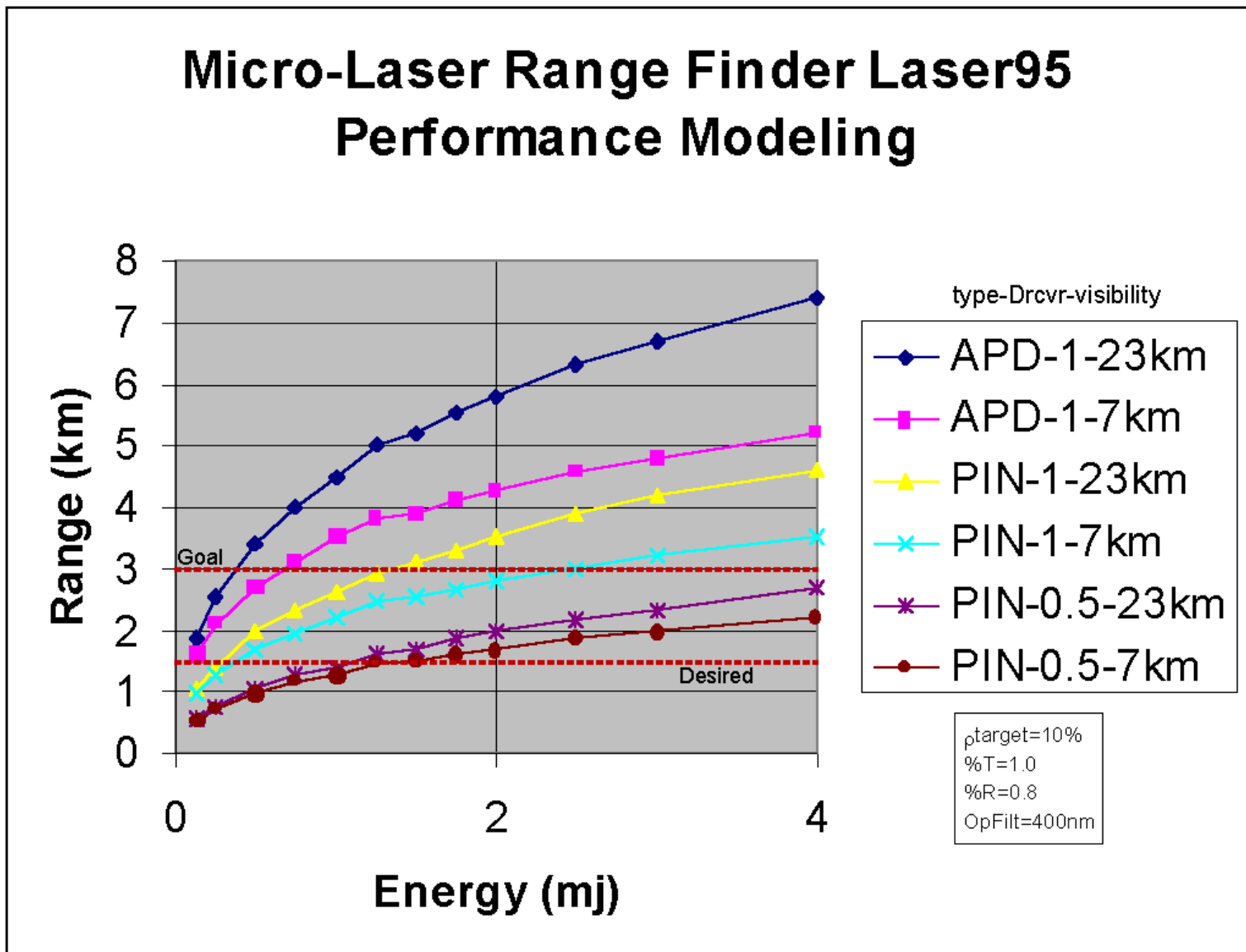

Figure 6. Modeled performance for the m LRF.

Use of the laser prediction model assists in determining design parameters. For example, using a 1 inch receiver PIN InGaAs detector system and the minimum required range specified as 1,500 meters, the model indicates about 500 microjoules laser output will be sufficient to perform as required. To meet a goal of 3,000 meters, using the same PIN system, about 2.5 millijoules are required. Whereas, if a 1 inch receiver APD InGaAs detector system is used, only 700 microjoules is needed to range out to 3,000 meters.

LABORATORY RESULTS

EXPERIMENTATION – Battery Life Testing for Flash Operation

The question arose, "How many shots will the mLRF get per AA battery?" so a quick experiment was conducted to answer the battery life question. The laboratory setup consisted of a single-board computer controller, a flash circuit, a photo-detector and a flash initiation circuit as depicted in Figure 7.

FLASH LAMP - BATTERY LIFE TESTING EXPERIMENT SETUP

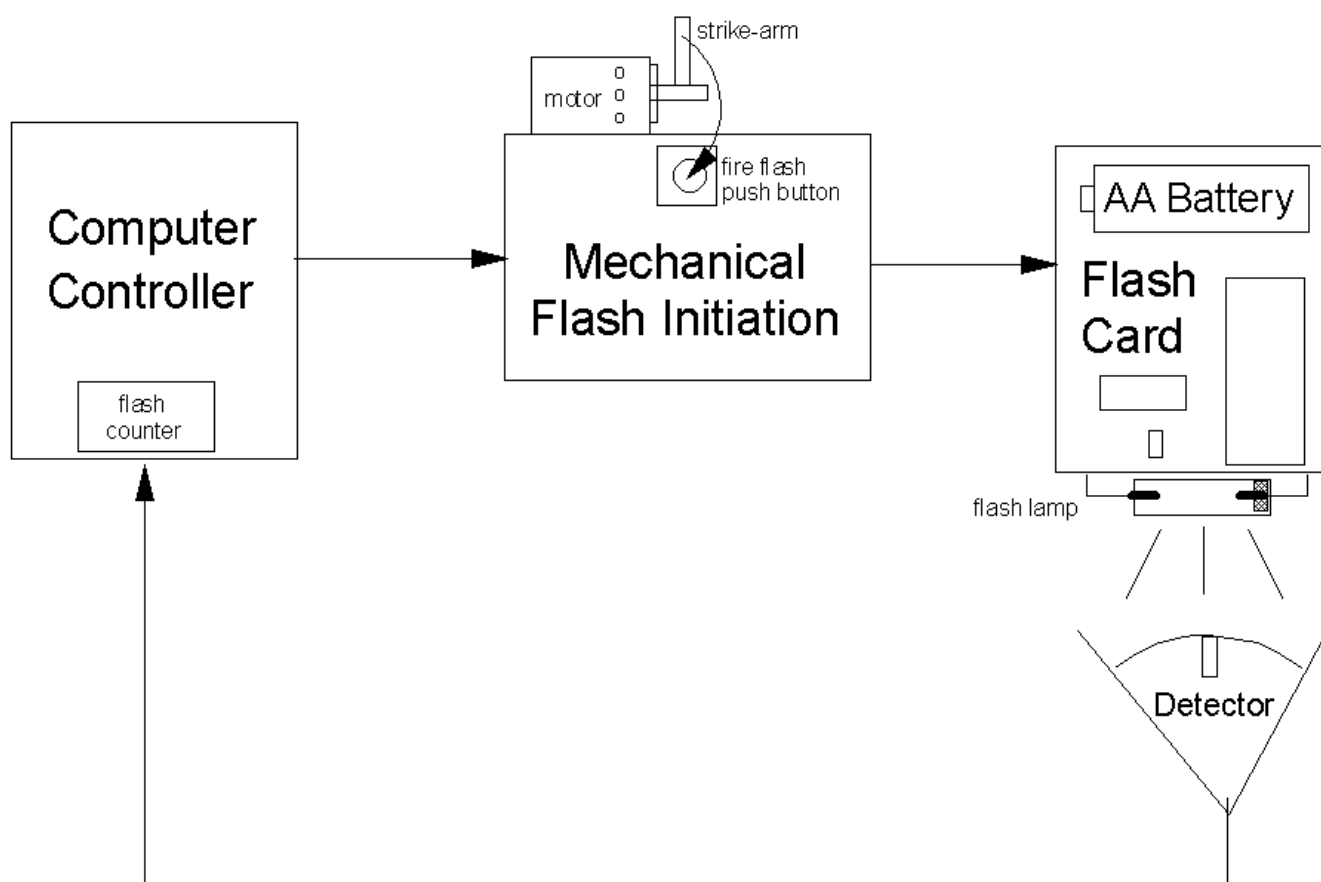

Figure 7. Battery life testing for flash.

The computer signaled the flash to fire every 15 seconds (as required in the Pocket Laser Range Finder Specifications). The flash unit has the opportunity to charge for the entire 15 seconds. The mechanical flash initiation circuit converted the electrical signal into a mechanical motion of a small strike-arm hitting the fire flash button. If the flash driver was properly charged the flash lamp would then fire. The photo-detector detects the flash lamp discharge and signals the flash counter to increment its count. The counter stopped its flash counting when the flash failed to operate 4 consecutive times (one minute).

A variety of manufactured AA batteries were obtained for this battery life testing experiment. The list includes alkaline Kodak, Duracell, Energizer, Rayovac and Sears Diehard, a lithium Energizer, and an Eveready standard dry cell.

The results of the single AA battery life testing are graphically depicted in the chart shown in Figure 8.

Flash Lamp - Battery Life Testing Results

Single AA Battery

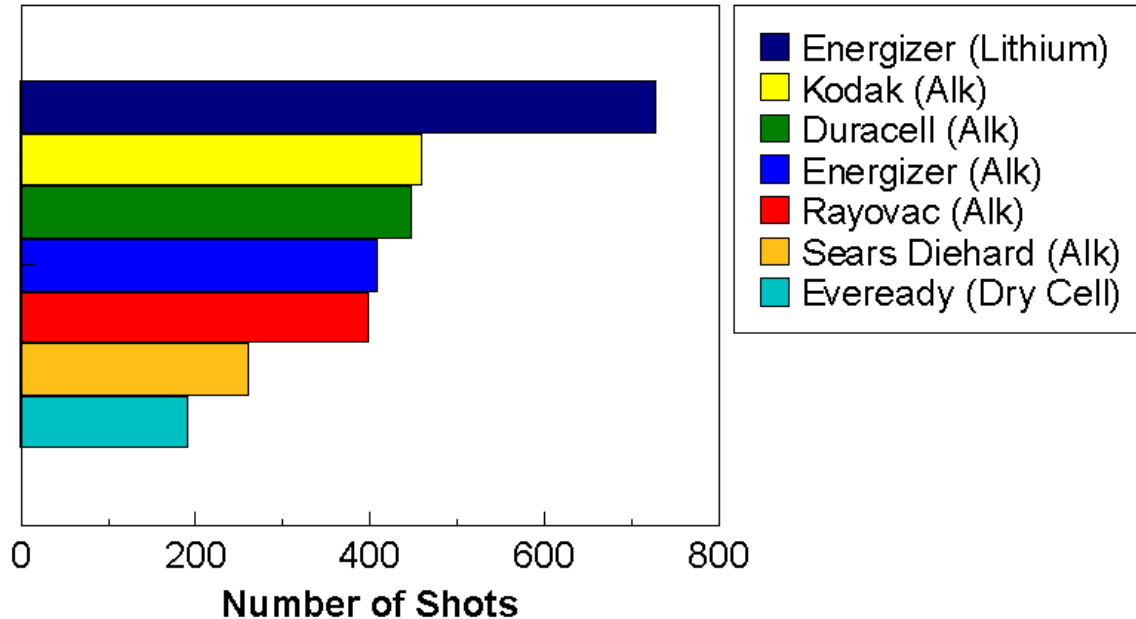

Figure 8. Battery life testing results.

The alkaline batteries performed very well (except for the Sears Diehard) while the lithium battery performed extremely well. Specifications require the system to 'have a minimum battery life of 250 ranging operations with internal battery source'. A single, size AA alkaline battery exceeds (>400 shots) this requirement for laser flash operation while a single, size AA lithium battery far exceeds (>700 shots) this specification. The standard dry cell, size AA falls a little short (~200 shots) of the required number of shots for the PLRF system.

NOTE: Flash lamp operation does not guarantee proper laser operation threshold has been achieved. A battery life time experiment with the complete laser cavity design must be performed to determine the number of useful range operations from a single size AA battery.

LASER CHARACTERIZATION

Pulse Width

The Monolithic Laser Cavity (MLC) module of the mLRF system (as seen in Figure 2) was characterized at NVESD. The pulse width of the laser output is displayed in Figure 9. The intra-cavity OPO pulse width (~28nsec) is approximately 4 times that of a comparable external cavity OPO (~7 nsec). Yet, the benefits of requiring fewer parts and giving more energy out coupled with the fact that the InGaAs PIN detector is optimized for operation with a 28 nsec pulse forced the selection of an intra-cavity OPO in the MLC module.

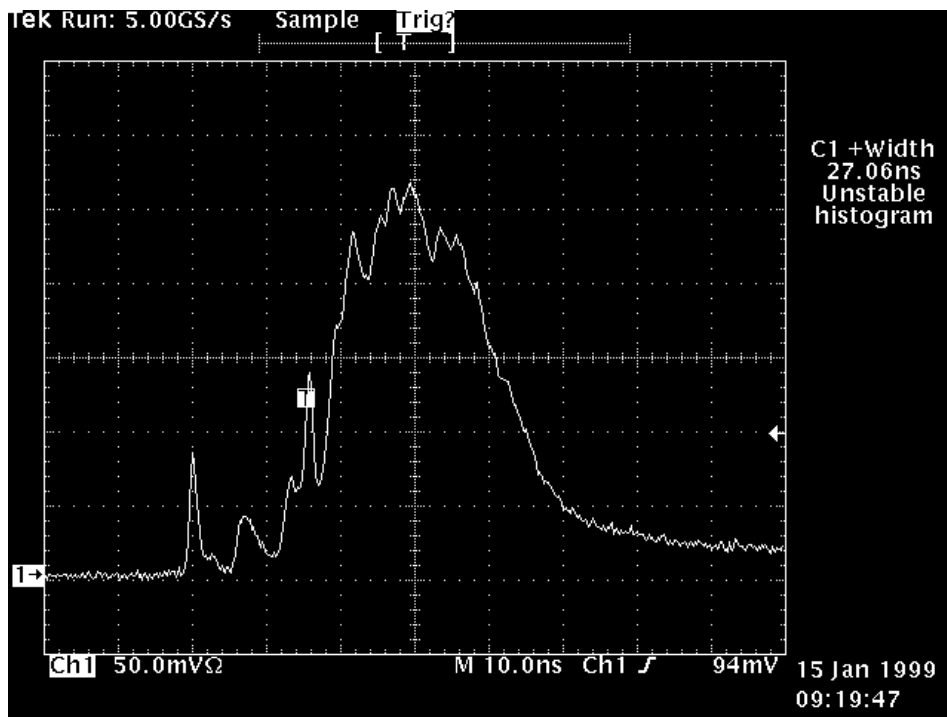
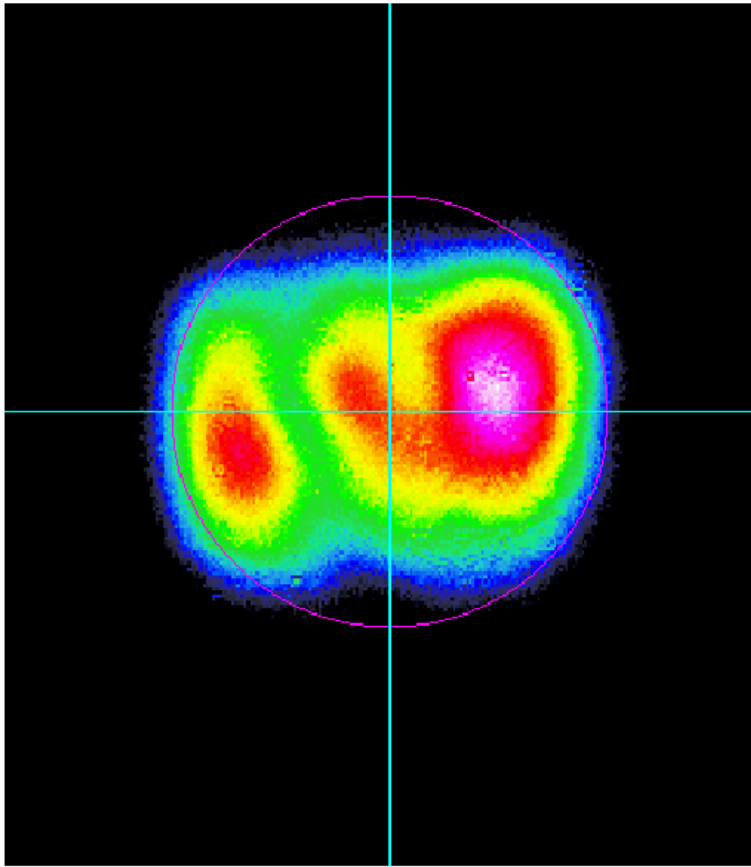

Figure 9. Pulse width measurement of the Monolithic Laser Cavity (MLC)

Beam Divergence

The quality of the MLC output beam is very important in that it will determine the size of the telescope required to collimate the beam with the desired divergence. Figure 10 shows the raw beam of the MLC laser output.



Raw Beam
(8 mRad aperture)

Raw Beam
(3D Representation)

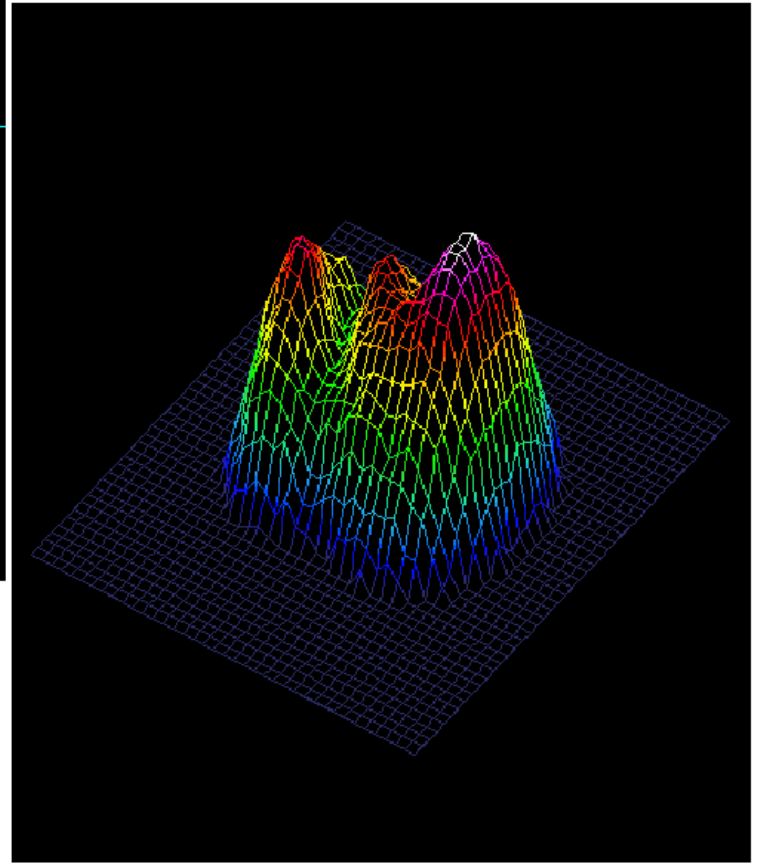
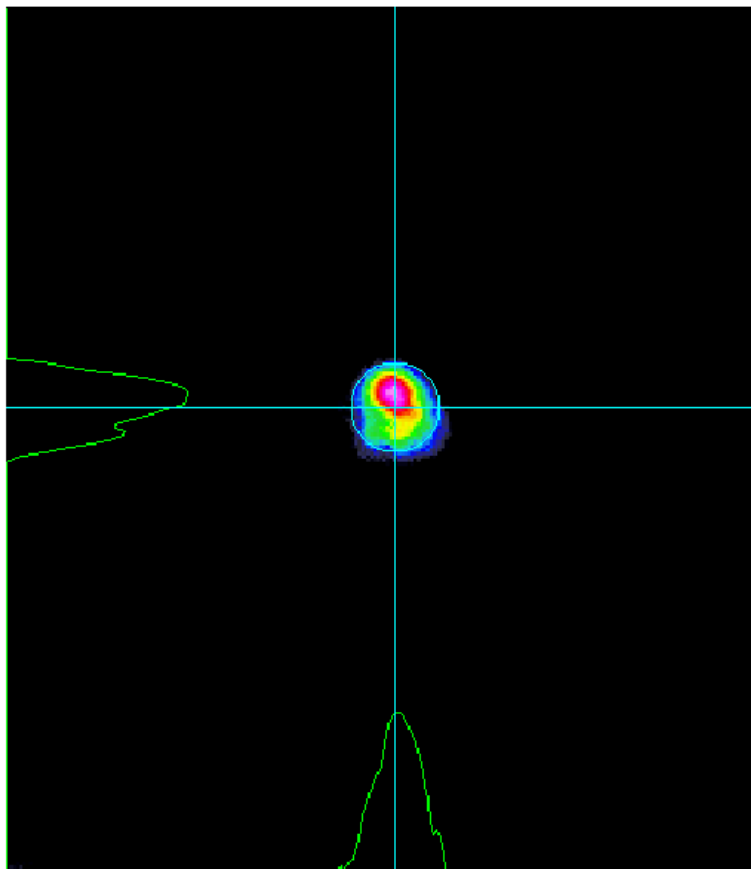

Figure 10. MLC's raw beam divergence.

The raw beam is directed through an 8x telescope. Figure 11 depicts this collimated beam. The diameter of the beam exiting the telescope was measured to be about 10-12 millimeters.



Collimated Beam (8x)
(1 mRad aperture)

Collimated Beam (8x)
(3D Representation)

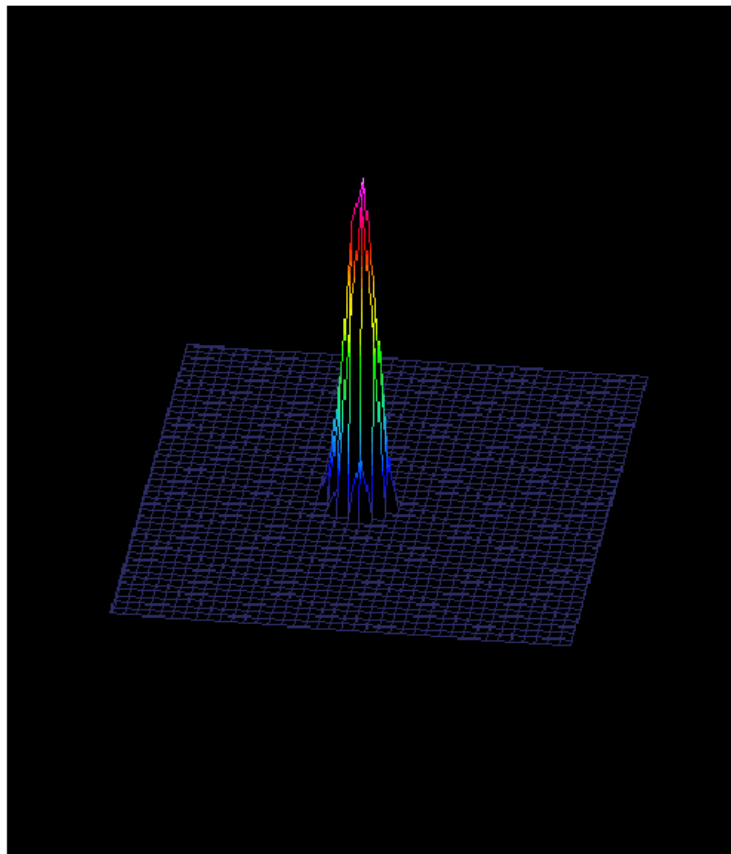

Figure 11. MLC collimated beam divergence.

Laser Energy Output

The MLC's energy output at 1.5 microns was measured to be over 4 millijoules as seen in Figure 12. When an optical mount was used for precise alignment, over 7 millijoules of 1.5 micron laser output was measured. Unfortunately, during the bonding process the optical alignment shifted and the energy output dropped to about 2.6 millijoules. The MLC concept has been validated. The components were dropped into place and bonded into place... no mechanical optical mounts are in the cavity!

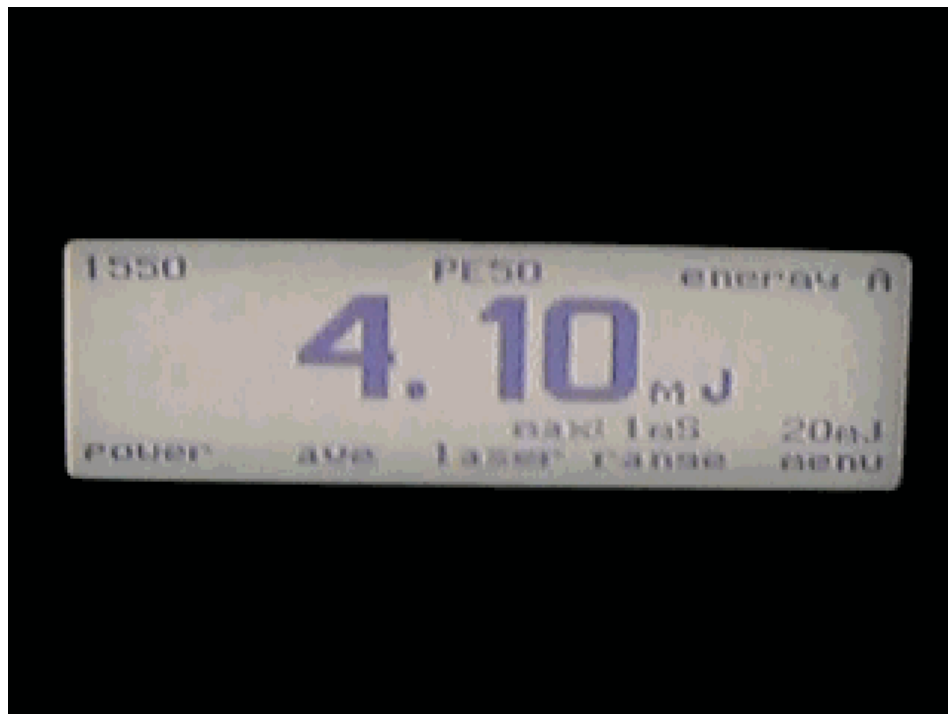

Figure 12. MLC's 1.5 micron output energy.

Penthouse Testing

The MLC was coupled with the 8x telescope and aligned with a 1 inch photoreceiver using a PIN InGaAs detector (as modeled using Lasers95). The START and STOP signals of the mLRF lab prototype were looked at using a wideband digitizing oscilloscope. Figure 13 is a replica of the scope's display from a copy of targets. The top trace is from a house across the bay about 3 km away and the bottom trace is from a house down the Potomac River about 7 km away (it was about a 10 km visibility day). The mLRF laboratory prototype used is shown in Figure 14.

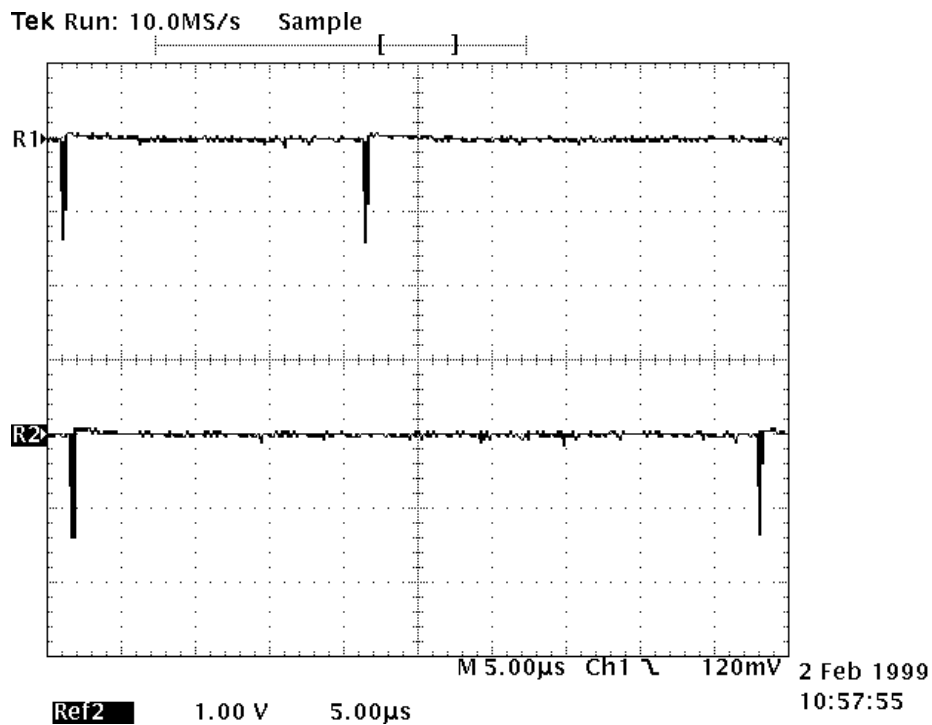

Figure 13. mLRF START and STOP signals on scope display.

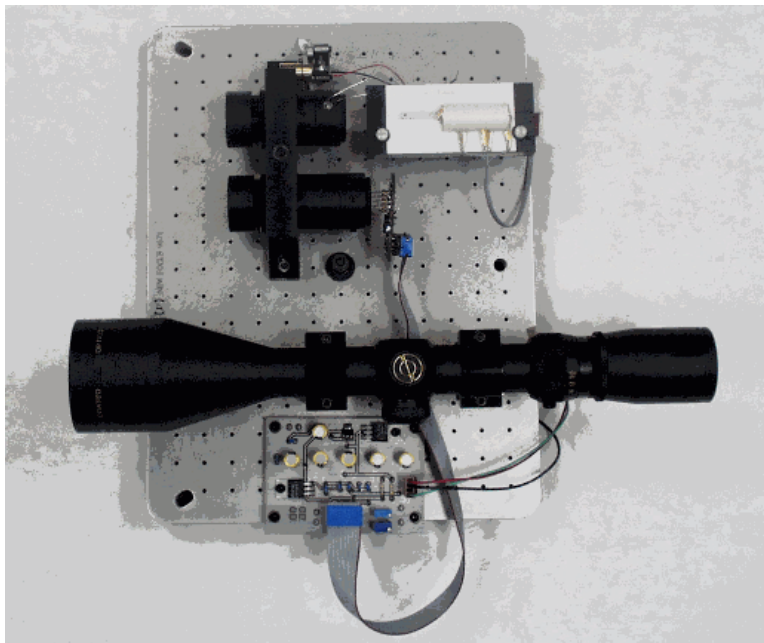

Figure 14. mLRF Laboratory Prototype.

FUTURE EFFORTS

The fabrication of a single electronics card which will contain the flash PFN, the power conditioning, the microprocessor controller, display driver, and the time-of-flight range processor is planned for completion by early March 99.

In order to address producibility issues, 10 Monolithic Laser Cavities (MLC) will be fabricated and then 10 Monolithic Laser Transceivers (MLT) will be fabricated.

Sets of the electronics card and MLT will be delivered to weapons integration houses for packaging. The complete package, which includes the electronics, MLT, housing and weapon mount will weigh less than 1.25 pounds. The packaged prototypes will undergo limited user testing this summer.

Additional efforts will be to investigate PFN energy conservation schemes, investigate alternatives to the PIN InGaAs photoreceiver, and investigate alternatives to Nd:YAG as the solid state laser material.

SUMMARY

The mLRF project is on the road to success. The Monolithic Laser Cavity (MLC) was proved viable. In house fabrication of the MLC at NVESD, characterization of the MLC that exceeded specifications, and ranging of the mLRF laboratory prototype system all point to a successful project. The achievement of function, form and affordability of the mLRF system appears to be very feasible.

The MLC module requires none of the labor extensive alignment procedures as current laser range finders. No optical holders have to be fabricated, no complex engineering is required to design the optical cavity, and no precise laser cavity alignment(s) are required. Production labor and material costs can be greatly reduced.

The mLRF's MLC simplifies the producibility of a laser range finder system. The fabrication of the mLRF can be done using batch processing. Large rectangular, pre-coated optical components can be joined together, optically aligned to form the laser cavity and then sliced to produce MLC modules. This batch process can greatly reduce the overall fabrication costs of the mLRF system.