7H

**Agilent 10716A High-Resolution
Interferometer**

Description

Description

The Agilent 10716A High Resolution Interferometer (see Figure 7H-1) offers twice the resolution of conventional plane mirror interferometers and has the same excellent thermal characteristics as the Agilent 10706B interferometer (typically, only 0.04 micron of drift per degree C). Measurement drift is typically 1/12 of that exhibited by a conventional plane mirror interferometer. These features result in improved accuracy, repeatability, and positioning capability.

Although the Agilent 10716A interferometer is larger than the conventional plane mirror interferometer and the slew rate is halved, the finer resolution of this optic allows laser measurement system measurement resolution of 2.5 nanometers (0.1 microinch) with most Agilent laser electronics.

The Agilent 10716A interferometer can be used in the same applications as other Agilent plane mirror interferometers, but with different alignment techniques. A turned configuration (Agilent 10716A-001) is available to turn the beam 90 degrees, thereby eliminating the need for a beam bender. Like other plane mirror interferometers the Agilent 10716A uses plane mirror reflectors such as the Agilent 10724A Plane Mirror Reflector or a suitable user-supplied plane mirror.

Figure 7H-2 shows the optical schematic of the Agilent 10716A High Resolution interferometer. The unit consists of a cube corner, a plane mirror converter, a retroreflector, a high-stability adapter, and a polarizing beam splitter.

Description

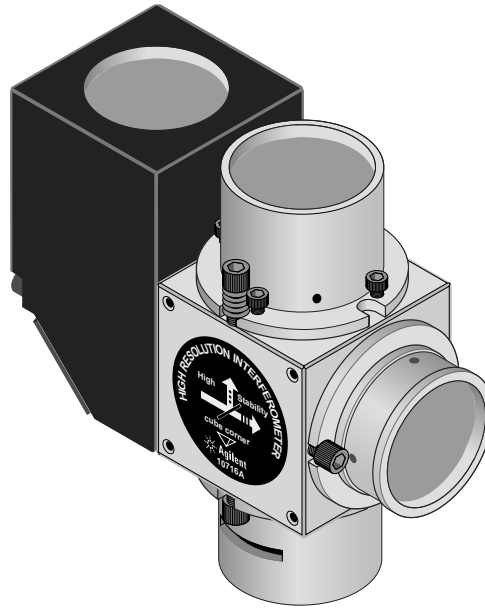

**Agilent 10716A
High Resolution Interferometer**

Figure 7H-1. Agilent 10716A High Resolution Interferometer

Chapter 7H Agilent 10716A High-Resolution Interferometer
Description

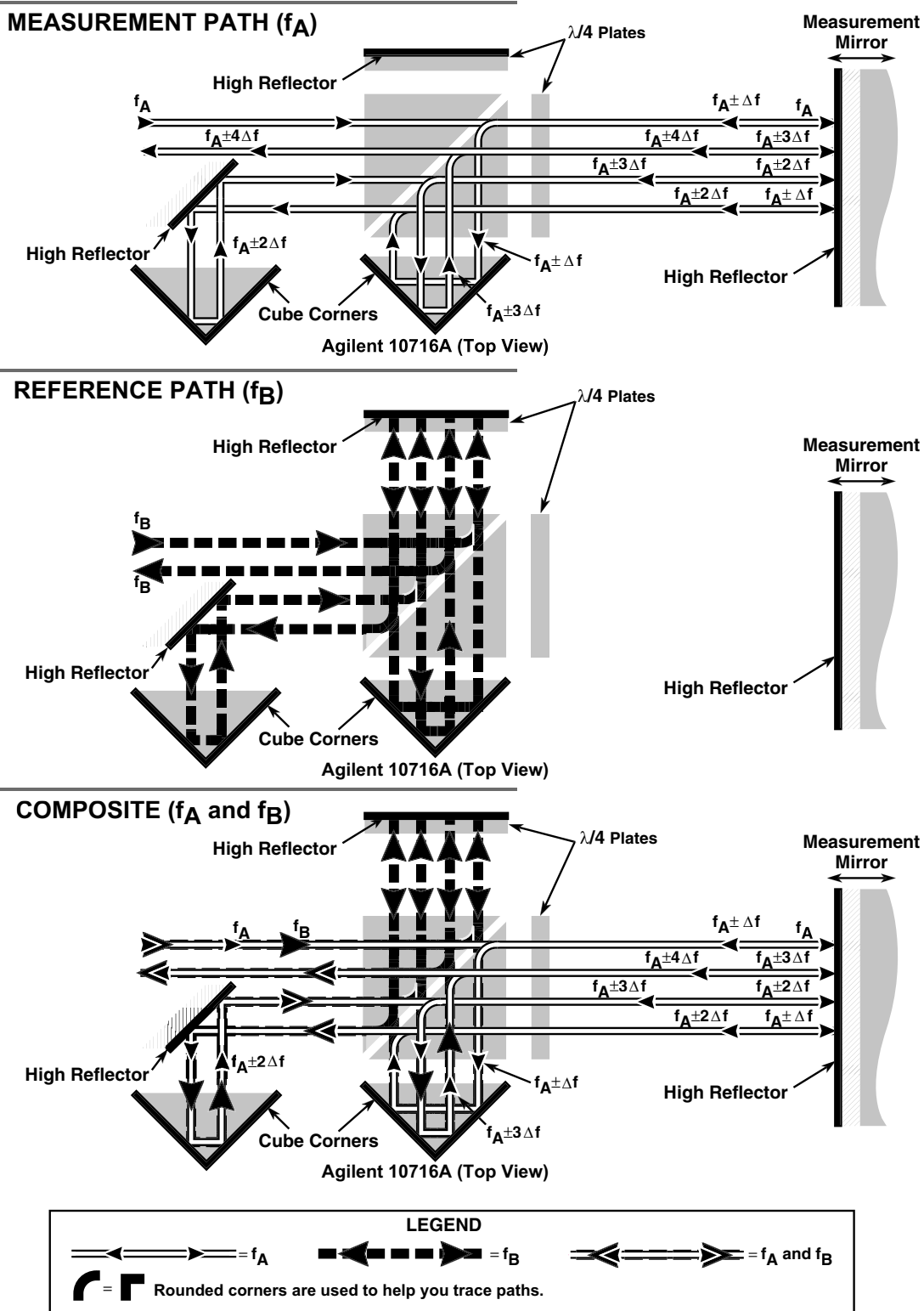

Figure 7H-2. Agilent 10716A High Resolution Interferometer, optical schematic

Special Considerations

Mounting

Adjustable mounts

The Agilent 10711A Adjustable Mount provides a convenient means of mounting, aligning, and securely locking the Agilent 10716A interferometer in position. Since the mount allows some tilt and yaw adjustment, the need for custom fixturing is minimized. The mount allows the interferometer to be rotated about its centerline, simplifying installation.

Fasteners

The Agilent 10716A interferometer is supplied with English mounting hardware, which is required to fasten it to its adjustable mount.

Installation

Pre-installation checklist

In addition to reading chapters 2 through 4, and Chapter 15, “Accuracy and Repeatability,” complete the following items before installing a laser positioning system into any application.

- Complete Beam Path Loss Calculation (see “Calculation of signal loss” in Chapter 3, “System Design Considerations,” of this manual).
- You must supply the plane mirror reflectors if the Agilent 10724A Plane Mirror Reflector will not work for your installation. See Chapter 15, “Accuracy and Repeatability,” Chapter 6, “Beam-Directing Optics,” or Chapter 7, “Measurement Optics,” in this manual for mirror specifications.
- Determine the direction sense for each axis, based on the orientation of the laser head, beam-directing optic, and interferometer. Enter the direction sense for each axis into the measurement system electronics. (See Chapter 5, “Laser Heads,” Chapter 14, “Principles of Operation”, and Chapter 15, “Accuracy and Repeatability,” in this manual.
- Provide for aligning the optics, laser head, and receiver(s) on the machine. (Ideally, you want to be able to translate beam in two directions and rotate beam in two directions for each interferometer input. This typically takes two adjustment optics with proper orientations.)

Alignment

- Be sure to allow for transmitted beam offset of beam splitters (Agilent 10700A and Agilent 10701A) in your design. (See the offset specifications under the “Specifications and Characteristics” section at the end of this subchapter.)

Alignment

The objective of these instructions is to align the Agilent 10716A to make measurements with 1) minimal cosine error and thermal drift and 2) maximum signal strength at the Agilent 10780C, Agilent 10780F, Agilent E1708A, or Agilent E1709A receiver.

The procedure below assumes that the plane mirror reflector is the movable optic and has been installed perpendicular to the axis of travel (see the Agilent 10724A installation procedure for details.).

Before proceeding with the alignment procedures, details on interferometer configurations and alignment aids are covered.

Configurations

The two configurations available for the High Resolution Interferometer allow flexibility in optical layout of a measurement system. They are:

- Standard
- Turned (10716-001)

Figures 7H-3 and 7H-4 illustrate the location of the measurement beams for each configuration.

AGILENT 10716A BEAM LOCATIONS

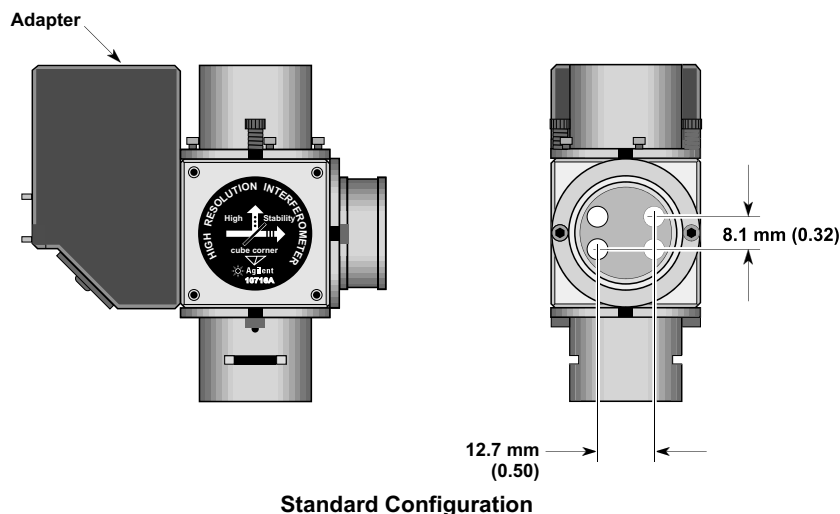
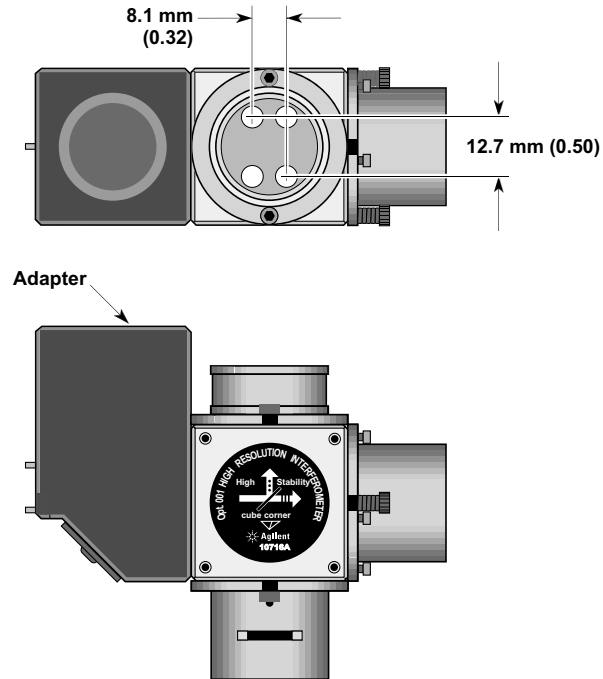

Figure 7H-3. Beam Locations for standard Agilent 10716A Interferometer

Alignment**Agilent 10716A-001 BEAM LOCATIONS****Turned Configuration****Figure 7H-4. Beam Locations for Agilent 10716A-001 Turned Configuration****Alignment Aids**

The Agilent 10716A High Resolution Interferometer is supplied with two of the alignment aids shown in Figure 7H-5.

- Alignment Aid, Agilent Part Number 10706-60001
- Alignment Aid, Agilent Part Number 10706-60202

Alignment Aid Agilent Part Number 10706-60202 eases the autoreflexion alignment for the high stability adapter to achieve minimal thermal drift and maximum signal strength. It contains a quarter-wave plate to reflect the reference beam back on itself and return it to the laser without offset. Figure 7H-8 shows how the aid is positioned between the beam splitter and the high stability adapter during alignment.

ALIGNMENT AIDS FOR AGILENT 10716A



**Alignment Aid
P/N 10706-60001**

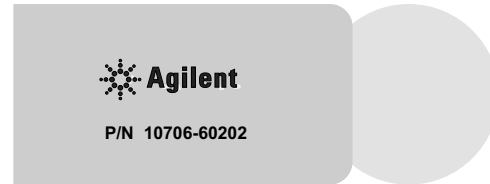
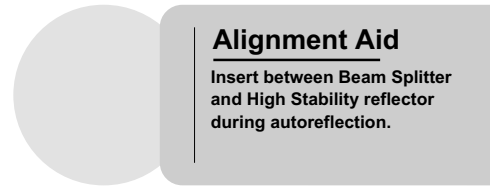

**Alignment Aid
P/N 10706-60202**

Figure 7H-5. Alignment Aids for the Agilent 10716A Interferometer

Alignment Overview

The alignment procedure is a five-part process.

- Alignment of the laser beam perpendicular to the plane mirror reflector using autoreflection.
- Alignment of the Agilent 10716A Interferometer to the beam, using a reflective gage block and autoreflection.
- Realignment of the laser beam, to correct for slight angular beam deviation caused by the interferometer.
- Alignment of the reference reflector in the interferometer, for minimum thermal drift and maximum signal strength.
- Installation of the Agilent 10780C, Agilent 10780F, Agilent E1708A, or Agilent E1709A receiver to properly receive the reference and measurement beams.

Alignment

Alignment Procedure

This alignment procedure is for the “Standard Configuration”, with the laser beam entering the interferometer in aperture B. The alignment procedure for the “Turned Configuration” is similar, except it is more sensitive to angular alignment of the interferometer.

NOTE

Either aperture A or B of the interferometer may be used as the input aperture. The remaining aperture is the output.

- 1 Select the small aperture on the laser head.
- 2 The laser beam for each axis should be aligned perpendicular to the measurement mirror. This is done by autoreflecting off this mirror and adjusting the laser head or beam bender until the reflected beam is centered in the small aperture on the laser head.
- 3 Move the interferometer so the laser beam enters the input aperture (aperture B, in this example).
- 4 Place a rectangular gage block over the input aperture so the laser beam is reflected back toward the laser. (See Figure 7H-6.)
- 5 Adjust the interferometer in pitch and yaw until the laser beam is autoreflected back into the laser head, ensuring proper alignment. It may be necessary to move the interferometer again to center the laser beam on the input aperture. Use a piece of translucent tape to help observe the beam.
- 6 Remove the gage block.

Note that the autoreflection procedure above is used only to reduce clipping, and is not as critical as the autoreflection procedure used to reduce cosine error. As long as the four beams are not clipped, the alignment of the interferometer is adequate.

The next steps refine the alignment to reduce cosine error.

- 7 Place the alignment aid (Agilent Part Number 10706-60001) over the output aperture (plane mirror converter) on the interferometer such that the measurement beam passes through the aperture on the alignment aid. (See Figure 7H-7.)

AGILENT 10716A WITH GAGE BLOCK

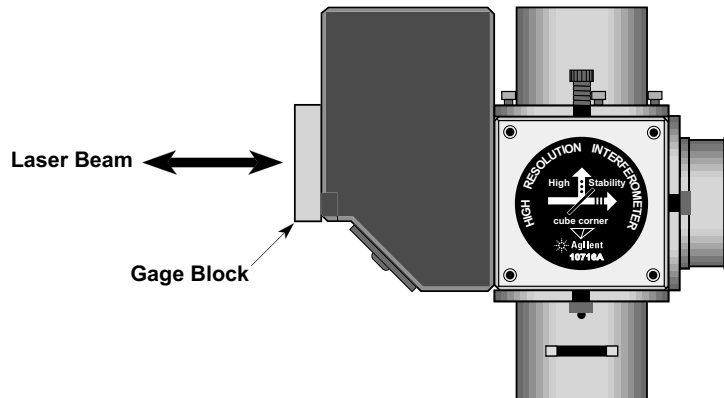

Figure 7H-6. Agilent 10716A with gage block attached

AGILENT 10716A USING 10706-60001 ALIGNMENT AID

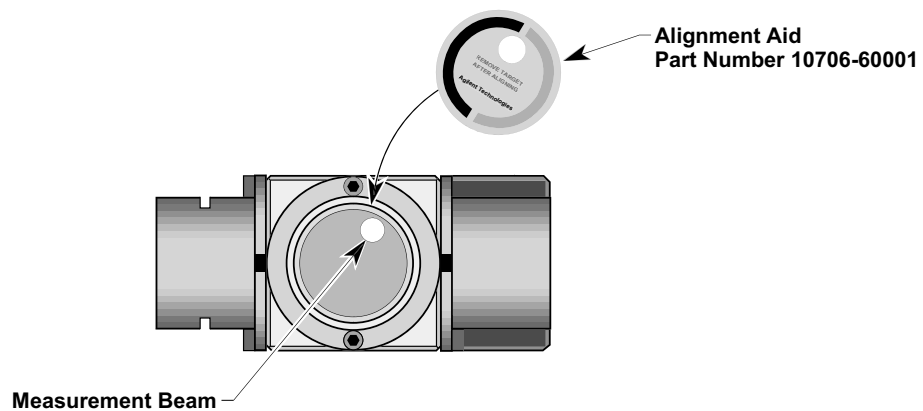

Figure 7H-7. Agilent 10716A with alignment aid attached over measurement beam

- 8** Select the small aperture on the front turret of the laser head. The return beam from the moving plane mirror may not autoreflect back to the small aperture of the laser head as it did in step 5. This must be corrected. Adjust the laser beam until the laser beam is perpendicular to the measurement mirror. This step requires pitching and yawing the laser head, beam benders, or beam splitters, depending on optical layout.
- 9** If substantial adjustment of the laser beam was required in step 8, the interferometer will have to be repositioned so that the beam goes through the center of the input aperture. Repeat steps 1 through 5 and secure the interferometer to its mount.

Alignment

NOTE

The Agilent 10716A High Resolution Interferometer is now aligned for minimum cosine error. The final steps (10 through 23) will align the reference reflector for minimum thermal drift coefficient and maximum signal strength.

- 10** Remove the Plane Mirror Converter assembly (i.e., the quarter-wave plate) from the measurement side of the interferometer by loosening one cap screw and removing the other.
- 11** Block the measurement beam and select the small aperture on the laser head.
- 12** Insert the Alignment Aid (Agilent Part Number 10706-60202) between the now-exposed glass beam splitter and the reference reflector (the one with the four adjustment cap screws and two springs). See Figure 7H-8. This will allow the reference beam to autoreflect back toward the small aperture on the laser head.
- 13** Return light will now be visible from this reflector near the laser output aperture.
- 14** Now adjust TWO of the small cap screws on the housing so that this return beam autoreflects back into the small output aperture of the laser.
- 15** GENTLY snug the other two cap screws while observing the return beam on the output aperture. Preserve the beam alignment.
- 16** Remove the alignment aid (Agilent Part Number 10706-20202) and replace the Plane Mirror Converter.
- 17** Unblock the measurement beam.
- 18** Verify autoreflection of the measurement beam by attaching the magnetic alignment aid to the output (measurement) side of the interferometer and observing the autoreflected beam on the laser aperture. Remove the magnetic alignment aid.
- 19** Verify that you now see four unclipped spots in a rectangular pattern on the face of the measurement plane mirror. (The room lights may have to be dimmed to see these weak spots of scattered light.)
- 20** Install the Agilent 10780C or Agilent 10780F Receiver so that light from the top aperture ("A" aperture) of the interferometer enters the center of the lens, parallel to the optical axis of the lens.

- 21 With a piece of translucent tape over the lens, verify that the spots from Reference and Measurement beams overlap adequately.

USING THE AGILENT 10706-60202 ALIGNMENT AID

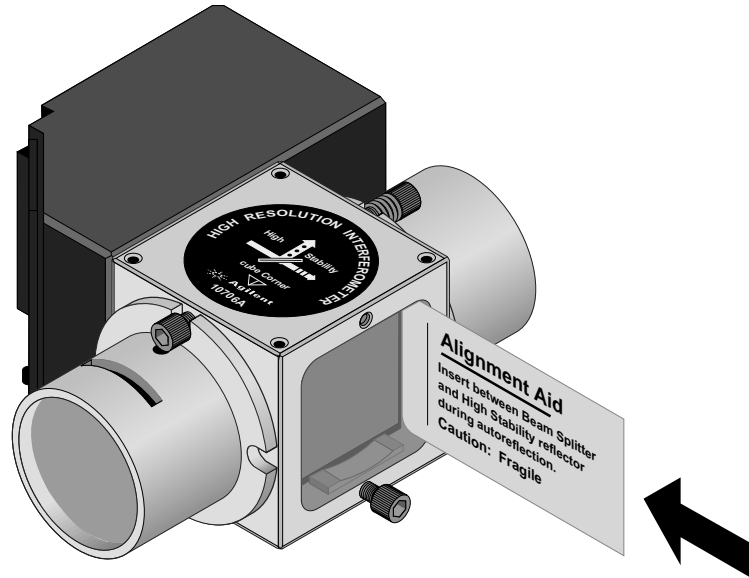

Figure 7H-8. Using the Agilent 10706-60202 Alignment Aid

- 22 If these spots do not overlap at the receiver, the alignment should be rechecked. It may be necessary to adjust the Reference Reflector adjustment screws to improve overlap.
- 23 Select the large aperture at the output of the laser head and traverse the full travel at the machine. Verify that the LED indicator on the receiver is lighted through the full travel and the voltage measured at the receiver test point is between 0.6 and 1.3 Vdc.

Specifications and Characteristics

Specifications describe the device's warranted performance. Supplemental characteristics (indicated by TYPICAL or NOMINAL) are intended to provide non-warranted performance information useful in applying the device.

Using electronic resolution extension, the system resolution is increased significantly. Depending on the system, an additional resolution extension factor of 32 (for Agilent 10885A and 10895A) or 256 (for Agilent 10897B and 10898A) is usually available.

Interferometer	Fundamental Optical Resolution	System Resolution 1 (see NOTE)	System Resolution 2 (see NOTE)
Agilent 10716A	$\lambda / 8$ (79.1 nm, 3.1 μin)	$\lambda / 256$ (2.5 nm, 0.1 μin)	$\lambda / 2048$ (0.31 nm, 0.012 μin)

NOTE

The system resolution 1 is based on using 32X electronic resolution extension. This is available with the Agilent 10885A and Agilent 10895A electronics.

The system resolution 2 is based on using 256X electronic resolution extension. This is available with the Agilent 10897B and Agilent 10898A electronics.

Agilent 10716A High Resolution Interferometer (and 10716A-001 Turned Configuration) Specifications

Weight: 502 grams (1.11 pounds)

Dimensions: see figure below

Materials Used:

- Housing: 416 Stainless Steel and 6061 Aluminum
- Spacers: Nylon
- Optics: Optical Grade Glass
- Adhesives: Low Volatility (Vacuum Grade)

Optical Efficiency: (including a 98% efficient plane mirror reflector and the Reference Mirror)

Typical: 30%

Worst Case: 25%

Thermal Drift Error:

(Change of indicated distance per degree C temperature change):
 0.05 micron/°C (1.6 μinch/°C) typical

Fundamental Optical Resolution: $\lambda / 8$

Non-linearity Error: ± 1 nanometer (0.04 microinch)

Maximum Transmitted Beam Deviation: 30 minutes of arc

Maximum Mirror Pitch/Yaw Tolerance:*

Depends on distance between mirror and interferometer.

Typical values are:

6 minutes for 152 mm (6 inches)

3 minutes for 305 mm (12 inches)

2 minutes for 508 mm (20 inches)

MEASUREMENT MIRROR RECOMMENDATIONS

Reflectance: 98% for 633 nanometers at normal incidence

Flatness: Depending on the application and accuracy requirements of the application, mirror flatness may range from $\lambda / 4$ to $\lambda / 20$; i.e., 0.16 to 0.03 μmeters (6 to 1.2 μinches).

Optical Surface Quality: 60 - 40 per Mil-0-13830

NOTE: Flatness deviations will appear as measurement errors when the mirror is translated across the beam. Mount should be kinematic so as not to bend mirror. If accuracy requirements demand it, mirror flatness might be calibrated (scanned and stored in the system controller) to be used as a correction factor.

*Misalignment of interferometer to measurement mirror will degrade the Thermal Drift Coefficient.

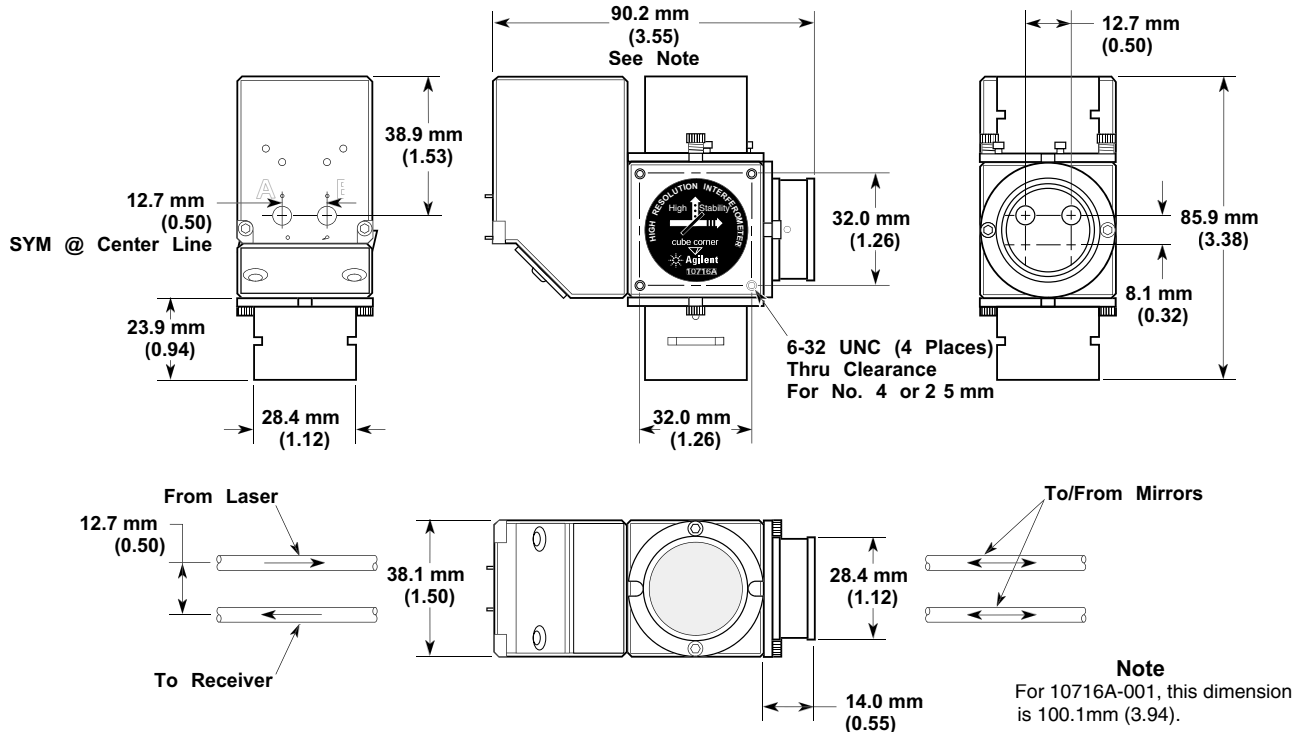

Figure 7H-9. Agilent 10716A High Resolution Interferometer (and Agilent 10716A-001 Turned Configuration)