

## Information Note

### 1.0 Introduction

The HP 58532A GPS L1 Reference Antenna is one component of a complete line of GPS accessories for your GPS antenna system available from Hewlett-Packard. These accessories are designed to deliver precise GPS signals over a wide temperature range and in harsh environmental conditions.

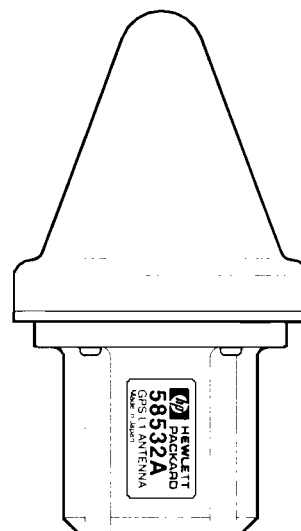

### 2.0 Description

The HP 58532A GPS L1 Reference Antenna delivers clean, accurate L1 carrier frequency signals to GPS synchronization modules and receivers. The antenna operates reliably in a wide range of environmental conditions, and it is characterized by durability, low noise, narrow bandwidth, and high gain.

Designed for outdoor locations, the HP 58532A Antenna features a threaded Type-N Jack connector that makes it easy to connect directly to the antenna cable. A mounting base (supplied) simplifies installation of the antenna to a mast.

The antenna requires a voltage of 5 Vdc, which is normally supplied from the GPS receiver via the connecting cable.

### 3.0 Installation

How an antenna is installed depends on a variety of local conditions. Hewlett-Packard offers several methods for mounting the antenna. These solutions include a mounting bracket or clamp to attach a mounting mast to a pipe, wall, or tripod. Contact HP as described below for ordering information and additional technical recommendations for installation.

#### Installation Information Available

- SEND a FAX message requesting the "GPS Installation Note" to **GPS Support** at **408-553-2058**. If you are outside the U.S.A., the Telephone Country Code is 1. Include your name and FAX number. The document describing the available GPS accessories and installation considerations will be sent back to you via FAX.

#### Installation Suggestions

1. Mount the antenna on a mast high enough above the surrounding surface to avoid standing water or snow.
2. A good location is one that is accessible, away from lightning rods, and one that provides a reasonably clear line of sight between the ground and satellites, from horizon to horizon.
3. Specific decisions on the optimum mounting location of the antenna and recommendations for proper lightning protection (such as lightning rods, arrestors, etc.) are unique to most installations and should be made by qualified personnel.

## Parts Supplied

- Antenna
- Mounting Base

Mounting base contains:

1. Four captive cross-recessed pan head screws for attaching to antenna (use small “cross point” (Phillips) screwdriver).
2. Two hex set screws (4 mm) for tightening antenna assembly to a mast.

## Optional Mounting Mast

A mounting mast is available as Option AUB to the antenna. If this option was not purchased with the antenna, it can be ordered from HP (part number 58532-20201). The mast is 355 mm in length with an outer diameter of 42 mm and made of either anodized aluminum or stainless steel. The inner diameter can also accommodate insertion of the HP 58529A Line Amplifier with L1 Bandpass Filter or the HP 58530A GPS L1 Bandpass Filter inside the mast for protection from the environment. **The mounting mast is warranted against defects in material and workmanship for 90 days.**

## Tools Required for Assembly

- Small “cross point” (Phillips) screwdriver for four cross-recessed pan head screws
- Hex wrench for 4 mm hex socket set screws

**NOTE:** If replacing an HP 58504A antenna with an HP 58532A, a Type-N Plug to TNC Jack adapter will be needed. If this was not ordered as Option 001 with the antenna, this adapter can be ordered from HP (part number: 1200-1897). **The adapter is warranted against defects in material and workmanship for 90 days.**

## 4.0 Dimensions of Antenna and Mounting Base

Figure 1 shows the major dimensions of the antenna and mount assembly.

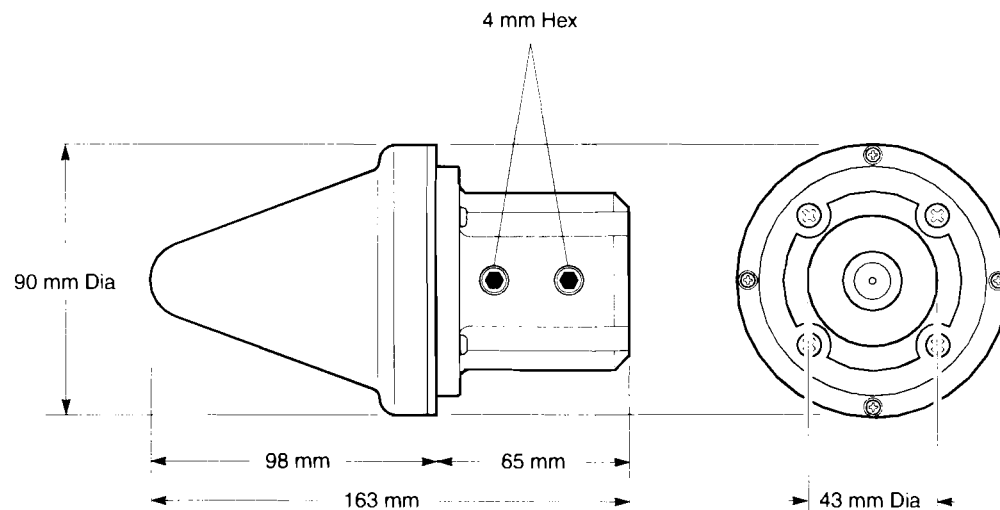

**Figure 1. HP 58532A GPS L1 Reference Antenna and Mounting Base Dimensions**

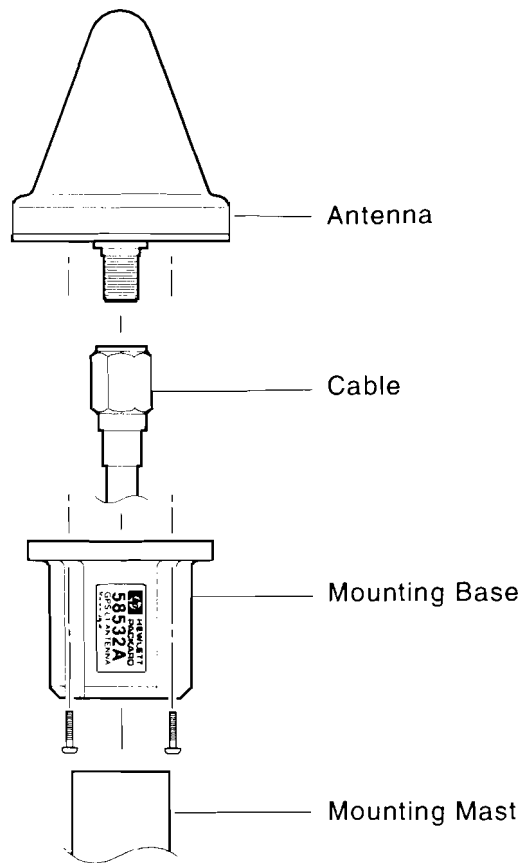

**Figure 2. Antenna Assembly Drawing**

**5.0 Assembly Procedure** (Refer to Figure 2 while following this procedure.)

1. Route the cable through the mast and the antenna mounting base.
2. Attach the cable to the antenna connector and tighten.

**NOTE:** It is recommended that all cable connections that are outdoors, or those connections exposed to wet or humid environments, be protected to prevent moisture condensation from entering the connectors. Consider wrapping the antenna-to-cable connection with a self-fusing insulating tape (for example, 3M Scotch™ 23 Rubber Splicing Tape).

3. Attach the antenna to the mounting base by tightening the four pan head screws into the antenna. Do not over-tighten.

**NOTE:** The gasket creates a very tight seal between the antenna and the mounting base. Consequently, extra pressure may be required to disassemble the antenna from the mounting base. Carefully use a flat-blade screwdriver as a wedge when disassembly is required.

4. Attach the antenna assembly to the mast by sliding the antenna assembly over the mast until the mast rests against the gasket at the top of the mounting base. Tighten the two set screws in the mount against the mast so the antenna assembly is securely held in place on the mast.

## 6.0 Maintenance

The only periodic maintenance for the antenna is to keep it clean and free of debris. The best cleaner is soap and water. Do not use abrasive compounds or chemical cleaners.

It is recommended that all components of the antenna system that are exposed to weather be checked periodically and replaced, if necessary.

## 7.0 Warranty

This Hewlett-Packard antenna product is warranted against defects in material and workmanship for a period of eighteen months from date of shipment. During the warranty period, Hewlett-Packard Company will, at its option, either repair or replace products which prove to be defective. In addition, the Option 001 adapter and the Option AUB mounting mast are warranted against defects in material and workmanship for 90 days from date of shipment.

### NOTICE

Lightning strikes are a natural occurrence. Any antenna system is susceptible to damage from a direct lightning strike or the radiated energy from a nearby lightning strike. DAMAGE OF THIS NATURE IS NOT COVERED BY HEWLETT-PACKARD'S WARRANTY.

## 8.0 Technical Data

**Table 1. HP 58532A Technical Characteristics**

<b>Electrical Characteristics</b>	All values are defined at 25° C ± 15° C, unless otherwise noted.
Frequency Range (3 dB Bandwidth)	1575.42 MHz ± 10 MHz (typical)
Polarization	Right-hand Circular
Impedance	50 Ω (typical)
Total Gain	> 30 dBi (38 dBi typical at elevation angle 90 degrees)
Out-of-Band Signal Attenuation	60 dB (typical) at 1575.42 MHz ± 50 MHz
Noise Figure	< 2.2 dB (1.8 dB typical)
VSWR	< 2.5 (1.5 typical)
DC Power	
Operating voltage	5 Vdc ± 0.5 Vdc
Operating current	< 27 mA (20 mA typical)

**Table 1. HP 58532A Technical Characteristics (continued)**

<b>Physical Characteristics</b>	
Dimensions	
Antenna without Mounting Base	90 mm Diameter x 128 mm Height (includes connector)
Mounting Base	43 mm Inner Diameter, 75 mm Outer Diameter x 65 mm Height
Mounting Mast (Option AUB)	39 mm Inner Diameter, 42 mm Outer Diameter x 355 mm Length
Weight	
Antenna without Mounting Base	187 g
Mounting Base	240 g
Mounting Mast (Option AUB)	250 g
Operating Temperature	-40° C to +85° C
Storage Temperature	-45° C to +90° C
Output Connector	Type-N Jack

**Antenna Amplitude vs. Frequency Response**

Figure 3 shows a relative amplitude vs. frequency response for the antenna as measured with a network analyzer. Note the steep roll-off characteristics of the filtering.

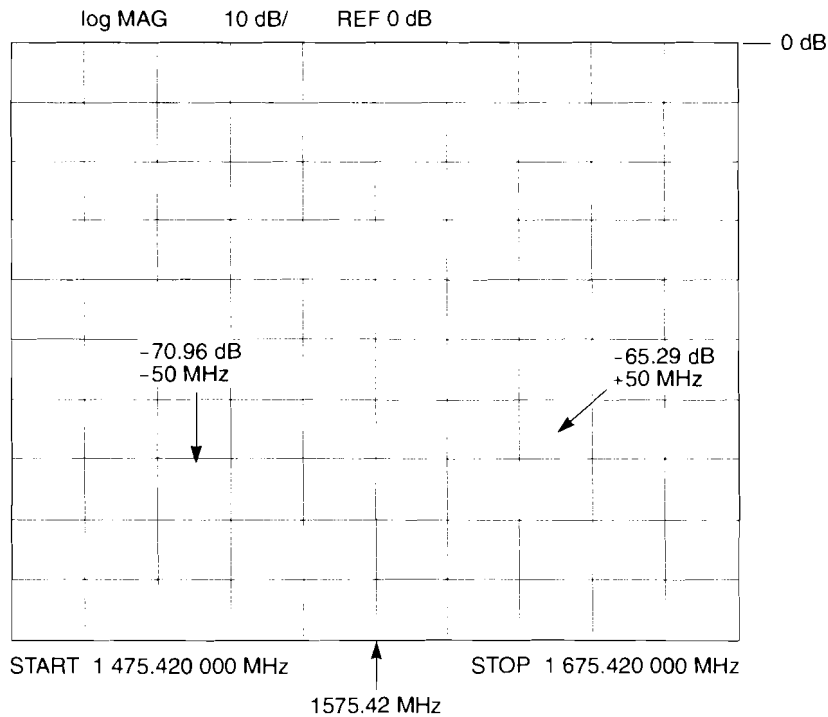

**Figure 3. Amplitude vs. Frequency Response for HP 58532A GPS L1 Reference Antenna**

## DECLARATION OF CONFORMITY

according to ISO/IEC Guide 22 and EN 45014

**Manufacturer's Name:** Hewlett-Packard Company

**Manufacturer's Address:** Santa Clara Division  
5301 Stevens Creek Boulevard  
Santa Clara, California 95052-8059  
U. S. A.

declares, that the product

**System Name:** Accessories, GPS Time and Frequency Receiver

<b>Component</b>	58504A Antenna	58505A/B Lightning Arrester
<b>Model Number and</b>	58509A/F Line Amplifier.	58512A 1:2 DA/Splitter
<b>Product Name:</b>	58513A Antenna Assembly	58514A Bandpass Filter
	58515A 1:2 DA/Splitter	58516A 1:4 DA/Splitter
	58517A 1:8 DA/Splitter	58532A Antenna
	58538A Lightning Arrester	58539A Lightning Arrester

**Product Options:** This declaration covers all options of the product.

conforms to the following Product Specifications:

**Safety:** IEC 1010-1: 1990 + A1 / EN 61010-1: 1993

<b>EMC:</b>	CISPR 22: 1993 / EN 55022:	1994	Class B
	IEC 801-2: 1991 / EN 50082-1:	1992	4 kV CD, 8 kV AD
	IEC 801-3: 1984 / EN 50082-1:	1992	3 V/m, 1kHz 80% AM, 26-1000MHz
	IEC 801-4: 1988 / EN 50082-1:	1992	0.5 kV Signal Lines & DC Power Port
	IEC 1000-3-2: 1995 /EN61000-3-2:1995		Harmonics
	IEC 1000-3-3: 1994 /EN61010-3-3:1995		Flicker

Supplementary Information:

The product models listed above comply with the requirements of the Low Voltage Directive 73/23/EEC and the EMC Directive 89/336/EEC and carries the CE marking accordingly.

Santa Clara, California, March 24, 1998

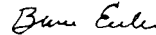

Bruce Euler, Quality Engineering Manager

European Contact: Your local Hewlett-Packard Sales and Service Office or Hewlett-Packard GmbH,  
Dept ZQ/Standards Europe, Herrenberger Straße 130, D-71034 Böblingen (FAX: +49-7031-143143)

Part Number: 58532-90001

Printed in U.S.A. June 1998